

# Shielded SMD Power Inductor – PSDB

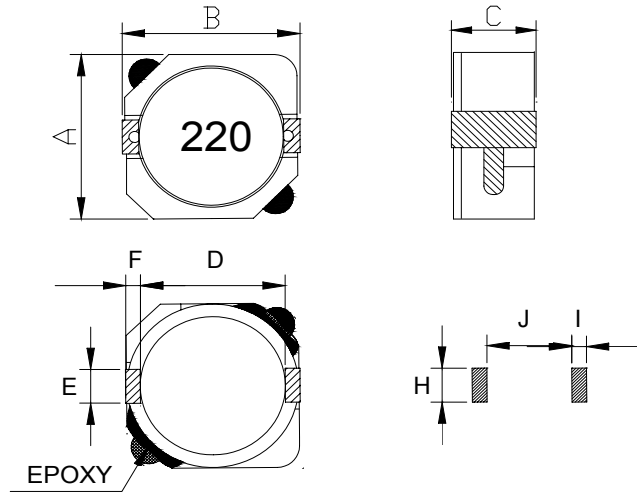

## Features

- Directly connected electrode on ferrite core
- High power, High saturation inductors
- Ideal inductors for DC/DC converters
- With magnetically shielded against radiation
- Available on tape and reel for automatic surface mounting.

## Applications

- Power Supply for VTRs
- LCD Televisions
- Notebook PCs
- Portable Communication
- DC/DC Converters, etc.

## Characteristics

- Rated DC current: The current when the inductance becomes 35% lower than its initial value or the actual current when the temperature of coil increases to  $\Delta T=40^{\circ}\text{C}$ . The smaller one is defined as Rated DC Current. ( $T_a=25^{\circ}\text{C}$ )
- Operating temperature range:  $-40\sim 85^{\circ}\text{C}$

## Dimensions

Unit: mm

Type	A max.	B max.	C max.	D	E	F	H	I	J
PSDB5D28	6.2	6.3	3.0	4.7	2.0	0.6	2.6	1.0	4.6
PSDB1003	10.3	10.4	3.1	7.7	3.0	1.2	3.2	1.6	7.3
PSDB1004	10.3	10.4	4.0	7.7	3.0	1.2	3.2	1.6	7.3
PSDB1005	10.3	10.4	5.0	7.7	3.0	1.2	3.2	1.6	7.3

## Inductance and rated current ranges

- PSDB5D28    2.5~100 $\mu\text{H}$     2.60~0.40A
- PSDB1003    10~150 $\mu\text{H}$     2.70~0.70A
- PSDB1004    1.3~330 $\mu\text{H}$     10.0~0.70A
- PSDB1005    1.5~1000 $\mu\text{H}$     10.5~0.35A
- Electrical specifications at  $25^{\circ}\text{C}$

## Product Identification

PSDB	5D28	N	T	101
Product Type	Dimensions (AxBxC)	Inductor Tolerance	Packaging Style	Inductance
	5D28: 6.2×6.3×3.0 1003: 10.3×10.4×3.1 1004: 10.3×10.4×4.0 1005: 10.3×10.4×5.0	N: $\pm 30\%$	T: Tape and Reel	1R1: 1.1 $\mu\text{H}$ 470: 47 $\mu\text{H}$ 101: 100 $\mu\text{H}$

## Electrical Characteristics

PSDB5D28 / 1003 / 1004 / 1005 Type

Codes	L ( $\mu$ H)	Tolerance	Test Condition	DCR (m $\Omega$ ) max.				IDC (A) max.			
				5D28	1003	1004	1005	5D28	1003	1004	1005
1R3	1.3	N	100KHz, 0.1V	-	-	8	-	-	-	10.0	-
1R5	1.5	N	100KHz, 0.1V	-	-	8	6	-	-	10.0	10.5
2R2	2.2	N	100KHz, 0.1V	-	-	11	7	-	-	8.00	9.25
2R5	2.5	N	100KHz, 0.1V	17.6	-	12	-	2.60	-	7.50	-
3R3	3.3	N	100KHz, 0.1V	20.3	-	13	10	2.30	-	6.50	7.80
3R8	3.8	N	100KHz, 0.1V	-	-	17	-	-	-	6.00	-
4R0	4.0	N	100KHz, 0.1V	27.0	-	-	-	2.10	-	-	-
4R7	4.7	N	100KHz, 0.1V	-	-	21	12	-	-	5.70	6.40
5R0	5.0	N	100KHz, 0.1V	31.1	-	-	-	1.85	-	-	-
5R2	5.2	N	100KHz, 0.1V	-	-	22	-	-	-	5.50	-
5R6	5.6	N	100KHz, 0.1V	-	-	25	-	-	-	5.20	-
6R0	6.0	N	100KHz, 0.1V	41.9	-	-	-	1.70	-	-	-
6R8	6.8	N	100KHz, 0.1V	-	-	26	18	-	-	4.90	5.40
7R0	7.0	N	100KHz, 0.1V	-	-	27	-	-	-	4.80	-
8R0	8.0	N	100KHz, 0.1V	49.9	-	-	-	1.50	-	-	-
8R2	8.2	N	100KHz, 0.1V	-	-	-	20	-	-	-	4.85
100	10	N	100KHz, 0.1V	54.0	58	35	26	1.30	2.70	4.40	3.45
120	12	N	100KHz, 0.1V	71.6	72	-	33	1.20	2.25	-	3.40
150	15	N	100KHz, 0.1V	82.4	86	50	41	1.10	2.22	3.60	2.83
180	18	N	100KHz, 0.1V	101.5	116	-	46	1.05	1.90	-	2.62
220	22	N	100KHz, 0.1V	119.0	145	73	61	0.95	1.78	2.90	2.44
270	27	N	100KHz, 0.1V	146.0	176	83	69	0.85	1.63	2.80	2.24
330	33	N	100KHz, 0.1V	182.5	213	93	84	0.76	1.46	2.30	1.88
390	39	N	100KHz, 0.1V	209.5	270	-	106	0.68	1.32	-	1.70
470	47	N	100KHz, 0.1V	229.5	299	128	130	0.60	1.18	2.10	1.56
560	56	N	100KHz, 0.1V	305.0	335	-	149	0.55	1.10	-	1.39
680	68	N	100KHz, 0.1V	351.0	451	213	201	0.48	1.04	1.50	1.36
820	82	N	100KHz, 0.1V	418.5	513	-	227	0.45	0.94	-	1.20
101	100	N	100KHz, 0.1V	520.0	700	304	253	0.40	0.84	1.35	1.09
121	120	N	100KHz, 0.1V	-	765	-	303	-	0.76	-	1.00
151	150	N	100KHz, 0.1V	-	876	506	370	-	0.70	1.15	0.91
181	180	N	100KHz, 0.1V	-	-	631	419	-	-	1.03	0.84
221	220	N	100KHz, 0.1V	-	-	756	500	-	-	0.92	0.75
271	270	N	100KHz, 0.1V	-	-	-	672	-	-	-	0.68
331	330	N	100KHz, 0.1V	-	-	1090	812	-	-	0.70	0.60
391	390	N	100KHz, 0.1V	-	-	-	953	-	-	-	0.57
471	470	N	100KHz, 0.1V	-	-	-	1289	-	-	-	0.50
561	560	N	100KHz, 0.1V	-	-	-	1430	-	-	-	0.47
681	680	N	100KHz, 0.1V	-	-	-	1599	-	-	-	0.43
821	820	N	100KHz, 0.1V	-	-	-	1768	-	-	-	0.39
102	1000	N	100KHz, 0.1V	-	-	-	1989	-	-	-	0.35