

# Anti-Corrosive Thin Film Precision Chip Resistor – PR Series

## Construction

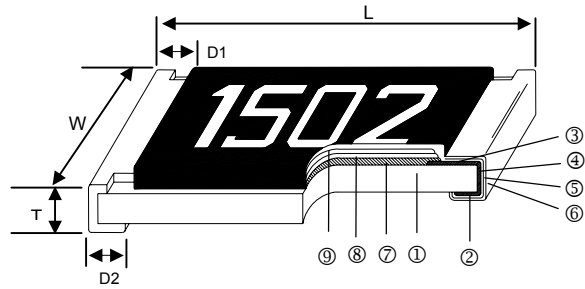

① Alumina Substrate	④ Edge Electrode (NiCr)	⑦ Resistor Layer (NiCr)
② Bottom Electrode (Ag)	⑤ Barrier Layer (Ni)	⑧ Passivation
③ Top Electrode (Ag-Pd)	⑥ External Electrode (Sn)	⑨ Overcoat

## Features

- Long term life stability and demonstrated the Anti-Corrosion claims characterized by Ta<sub>2</sub>N
- Special passivated NiCr film for Anti-Acid and Anti-Damp
- Tight tolerance down to ±0.1%
- Extremely low TCR down to ±15 PPM/°C
- Wide resistance range 10ohm ~ 1Mega ohm

## Applications

- Automotive
- High-end Computer
- Industrial Equipment
- Automatic Equipment Controller
- Medical Equipment
- Telecommunication Device
- High-end Multimedia Electronics
- Outdoor Electronic Applications

## Dimensions

Unit: mm

Type	Size (Inch)	L	W	T	D1	D2	Weight (g) (1000pcs)
PR02	0402	1.00±0.05	0.50±0.05	0.30±0.05	0.20±0.10	0.20±0.10	0.55
PR03	0603	1.55±0.10	0.80±0.10	0.45±0.10	0.30±0.20	0.30±0.20	1.85
PR05	0805	2.00±0.15	1.25±0.15	0.55±0.10	0.30±0.20	0.40±0.25	4.76
PR06	1206	3.05±0.15	1.55±0.15	0.55±0.10	0.42±0.20	0.35±0.25	9.11
PR10	2010	4.90±0.15	2.40±0.15	0.55±0.10	0.60±0.30	0.50±0.25	23.82
PR12	2512	6.30±0.15	3.10±0.15	0.55±0.10	0.60±0.30	0.50±0.25	38.46

## Derating Curve

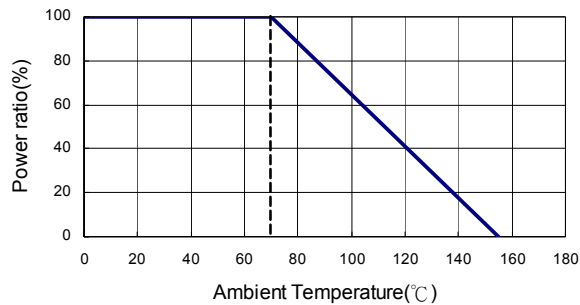

## Part Numbering

PR	03	D	T	D	X	1000	N
Product Type	Dimensions	Resistance Tolerance	Packaging Code	TCR (PPM/°C)	Power Rating	Resistance	Marking Code
	02: 0402 03: 0603 05: 0805 06: 1206 10: 2010 12: 2512	B: ±0.1% C: ±0.25% D: ±0.5%	T: Taping Reel B: Bulk	N: ±15 C: ±25 D: ±50	: Standard Y: 1/16W X: 1/10W W: 1/8W V: 1/4W U: 1/2W	1000: 100Ω 2201: 2200Ω 1001: 1KΩ 1004: 1MΩ	: Standard Marking for E96 / E24 N: No Marking

## Standard Electrical Specifications

Item Type	Power Rating at 70°C	Operating Temp. Range	Max. Operating Voltage	Max. Overload Voltage	Resistance Range			TCR (PPM/°C)
					±0.1%	±0.25%	±0.5%	
PR02 (0402)	1/16W	-55 ~ +155°C	25V	50V	49.9Ω - 12KΩ			±15
					25Ω - 25KΩ			±25 ±50
PR03 (0603)	1/16W	-55 ~ +155°C	50V	100V	25Ω - 332KΩ			±15 ±25 ±50
PR05 (0805)	1/10W	-55 ~ +155°C	100V	200V	10Ω - 1MΩ			±15 ±25 ±50
PR06 (1206)	1/8W	-55 ~ +155°C	150V	300V	10Ω - 1MΩ			±15 ±25 ±50
PR10 (2010)	1/4W	-55 ~ +155°C	150V	300V	25Ω - 1MΩ			±15
					10Ω - 1.5MΩ			±25 ±50
PR12 (2512)	1/2W	-55 ~ +155°C	150V	300V	25Ω - 1MΩ			±15
					10Ω - 1.5MΩ			±25 ±50

Operating Voltage= $\sqrt{P \cdot R}$  or Max. operating voltage listed above, whichever is lower.

Overload Voltage= $2.5 \cdot \sqrt{P \cdot R}$  or Max. overload voltage listed above, whichever is lower.

## High Power Rating Electrical Specifications

Item Type	Power Rating at 70°C	Operating Temp. Range	Max. Operating Voltage	Max. Overload Voltage	Resistance Range			TCR (PPM/°C)
					±0.1%	±0.25%	±0.5%	
PR03 (0603)	1/10W	-55 ~ +155°C	75V	150V	25Ω - 220KΩ			±15 ±25 ±50
PR05 (0805)	1/8W	-55 ~ +155°C	150V	300V	25Ω - 680KΩ			±15 ±25 ±50
PR06 (1206)	1/4W	-55 ~ +155°C	200V	400V	25Ω - 1MΩ			±15 ±25 ±50

Operating Voltage= $\sqrt{P \cdot R}$  or Max. operating voltage listed above, whichever is lower.

Overload Voltage= $2.5 \cdot \sqrt{P \cdot R}$  or Max. overload voltage listed above, whichever is lower.

## Environmental Characteristics

Item	Requirement		Test Method
	Size 0603 / 0805 / 1206 2010 / 2512	Size 0402	
Short Time Overload	$\leq \pm 0.02\%$	$\leq \pm 0.1\%$	RCWV*2.5 or Max. overload voltage for 2 seconds
	$\leq \pm 0.2\%$ for high power rating		
Endurance	$\leq \pm 0.05\%$	$\leq \pm 0.25\%$	70±2°C, Max. working voltage for 1000 hrs with 1.5 hrs "ON" and 0.5 hrs "OFF"
	$\leq \pm 0.25\%$ for high power rating		
Damp Heat with Load	$\leq \pm 0.05\%$	$\leq \pm 0.5\%$	40±2°C, 90~95% R.H. Max. working voltage for 1000 hrs with 1.5 hrs "ON" and 0.5 hrs "OFF"
	$\leq \pm 0.25\%$ for high power rating		
Solderability	95% min. coverage		245±5°C for 3 seconds
Resistance to Soldering Heat	$\leq \pm 0.02\%$	$\leq \pm 0.1\%$	260±5°C for 10 seconds
Thermal Shock	$\leq \pm 0.02\%$	$\leq \pm 0.1\%$	-55°C~150°C, 100 cycles

Reference Standards: MIL-STD-202, JIS-C 5201-1

Storage Temperature: 25±3°C; Humidity < 80%RH

## ■ Packaging

### Packaging Quantity & Reel Specifications

Unit: mm

Type	ΦA	ΦB	ΦC	W	T	Paper Tape (EA)	Embossed Plastic Tape (EA)
PR02	178.0 ± 1.0	60.0 + 1.0	13.5 ± 0.7	9.5 ± 1.0	11.5 ± 1.0	10,000	-
PR03	178.0 ± 1.0	60.0 + 1.0	13.5 ± 0.7	9.5 ± 1.0	11.5 ± 1.0	5,000	-
PR05	178.0 ± 1.0	60.0 + 1.0	13.5 ± 0.7	9.5 ± 1.0	11.5 ± 1.0	5,000	-
PR06	178.0 ± 1.0	60.0 + 1.0	13.5 ± 0.7	9.5 ± 1.0	11.5 ± 1.0	5,000	-
PR10	178.0 ± 1.0	60.0 + 1.0	13.5 ± 0.7	13.5 ± 1.0	15.5 ± 1.0	-	4,000
PR12	178.0 ± 1.0	60.0 + 1.0	13.5 ± 0.7	13.5 ± 1.0	15.5 ± 1.0	-	4,000

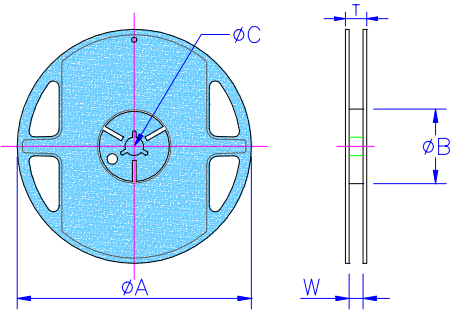

### Paper Tape Specifications

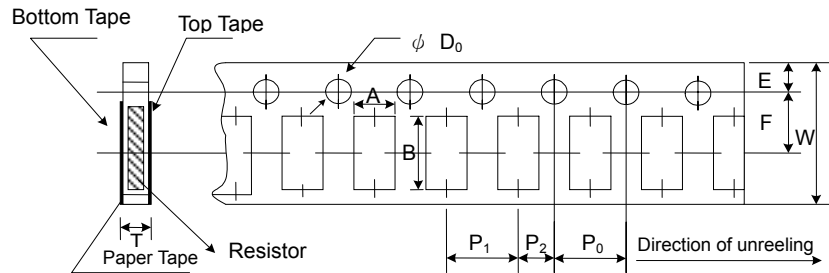

Unit: mm

Type	A	B	W	E	F	P <sub>0</sub>	P <sub>1</sub>	P <sub>2</sub>	ΦD <sub>0</sub>	T
PR02	0.70±0.05	1.16±0.05	8.00±0.10	1.75±0.05	3.5±0.05	4.00±0.10	2.00±0.05	2.00±0.05	1.55±0.05	0.40±0.03
PR03	1.10±0.05	1.90±0.05	8.00±0.10	1.75±0.05	3.5±0.05	4.00±0.10	4.00±0.10	2.00±0.05	1.55±0.05	0.60±0.03
PR05	1.60±0.05	2.37±0.05	8.00±0.10	1.75±0.05	3.5±0.05	4.00±0.10	4.00±0.10	2.00±0.05	1.55±0.05	0.75±0.05
PR06	2.00±0.05	3.55±0.05	8.00±0.10	1.75±0.05	3.5±0.05	4.00±0.10	4.00±0.10	2.00±0.05	1.55±0.05	0.75±0.05

### Embossed Plastic Tape Specifications

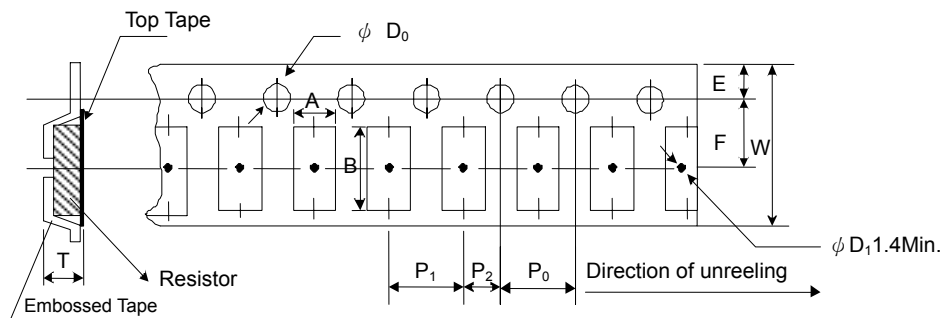

Unit: mm

Type	A	B	W	E	F	P <sub>0</sub>	P <sub>1</sub>	P <sub>2</sub>	ΦD <sub>0</sub>	T
PR10	2.85±0.10	5.45±0.10	12.0±0.10	1.75±0.10	5.5±0.05	4.00±0.05	4.00±0.10	2.00±0.05	1.50±0.10	1.00±0.20
PR12	3.40±0.10	6.65±0.10	12.0±0.10	1.75±0.10	5.5±0.05	4.00±0.05	4.00±0.10	2.00±0.05	1.50±0.10	1.00±0.20

## ■ Recommend Land Pattern

Unit: mm

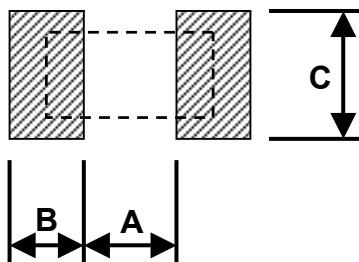

Type	A	B	C
PR02	0.50	0.50	0.60±0.2
PR03	0.80	1.00	0.90±0.2
PR05	1.00	1.00	1.35±0.2
PR06	2.00	1.15	1.70±0.2
PR10	3.60	1.40	2.50±0.2
PR12	4.90	1.60	3.10±0.2