

# Current Sensing Chip Resistor – CS Series

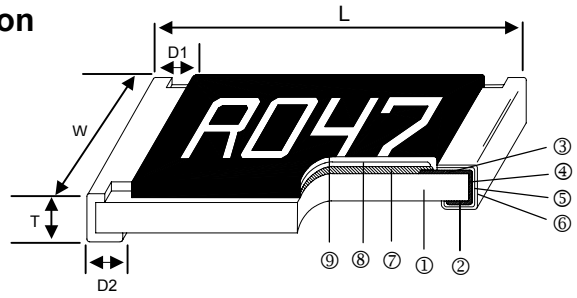

## Construction



① Alumina Substrate	④ Edge Electrode (NiCr)	⑦ Resistor Layer (Ag/Pd)
② Bottom Electrode (Ag)	⑤ Barrier Layer (Ni)	⑧ Primary Overcoat (Glass)
③ Top Electrode (Ag-Pd)	⑥ External Electrode (Sn)	⑨ Secondary Overcoat (Epoxy)

## Features

- 3 Watts power rating in 1 Watt size, 1225 package
- Low TCR of  $\pm 100$  PPM/ $^{\circ}$ C
- Resistance values from 1m to 1 ohm
- High purity alumina substrate for high power dissipation
- Long side terminations with higher power rating

## Applications

- Power Management Applications
- Switching Power Supply
- Over Current Protection in Audio Applications
- Voltage Regulation Module (VRM)
- DC-DC Converter, Battery Pack, Charger, Adaptor
- Automotive Engine Control
- Disk Driver

## Dimensions

Unit: mm

Type	Size (Inch)	L	W	T	D1	D2	Weight (g) (1000pcs)
CS01	0201	0.60 $\pm$ 0.03	0.30 $\pm$ 0.03	0.23 $\pm$ 0.05	0.12 $\pm$ 0.05	0.15 $\pm$ 0.05	0.18
CS02	0402	1.00 $\pm$ 0.05	0.50 $\pm$ 0.05	0.32 $\pm$ 0.10	0.25 $\pm$ 0.10	0.20 $\pm$ 0.10	0.7
CS03	0603	1.60 $\pm$ 0.10	0.80 $\pm$ 0.10	0.45 $\pm$ 0.10	0.30 $\pm$ 0.20	0.30 $\pm$ 0.20	1.99
CS05	0805	2.00 $\pm$ 0.10	1.25 $\pm$ 0.10	0.55 $\pm$ 0.10	0.30 $\pm$ 0.20	0.40 $\pm$ 0.25	5.3
CS06	1206	3.10 $\pm$ 0.10	1.55 $\pm$ 0.10	0.55 $\pm$ 0.10	0.50 $\pm$ 0.30	0.40 $\pm$ 0.25	8.82
CS13	1210	3.10 $\pm$ 0.10	2.60 $\pm$ 0.15	0.55 $\pm$ 0.10	0.50 $\pm$ 0.30	0.50 $\pm$ 0.25	15.5
CS10	2010	5.00 $\pm$ 0.10	2.50 $\pm$ 0.15	0.60 $\pm$ 0.15	0.60 $\pm$ 0.30	0.50 $\pm$ 0.25	27.03
CS12	2512	6.35 $\pm$ 0.10	3.10 $\pm$ 0.15	0.60 $\pm$ 0.10	0.60 $\pm$ 0.30	0.55 $\pm$ 0.25	43.08
CS12 (2W)	2512 10 - 99m $\Omega$	6.35 $\pm$ 0.20	3.15 $\pm$ 0.15	0.74 $\pm$ 0.10	0.60 $\pm$ 0.30	0.55 $\pm$ 0.25	53.08
CS12 (2W)	2512 100 - 1000m $\Omega$	6.35 $\pm$ 0.20	3.15 $\pm$ 0.15	0.74 $\pm$ 0.10	0.60 $\pm$ 0.30	2.10 $\pm$ 0.10	53.08
CS25	1225	3.10 $\pm$ 0.15	6.30 $\pm$ 0.15	0.90 $\pm$ 0.15	0.60 $\pm$ 0.30	0.55 $\pm$ 0.25	64.88
CS37	3720	2.00 $\pm$ 0.20	3.75 $\pm$ 0.20	0.60 $\pm$ 0.10	0.40 $\pm$ 0.20	0.40 $\pm$ 0.20	19.96
CS75	7520	2.00 $\pm$ 0.20	7.50 $\pm$ 0.30	0.60 $\pm$ 0.10	0.40 $\pm$ 0.20	0.40 $\pm$ 0.20	35.71

## Part Numbering

CS	06	F	T	G	U	R100	N
Product Type	Dimensions	Resistance Tolerance	Packaging Code	TCR (PPM/ $^{\circ}$ C)	Power Rating	Resistance	Marking
	01: 0201 02: 0402 03: 0603 05: 0805 06: 1206 13: 1210 10: 2010 12: 2512 25: 1225 37: 3720 75: 7520	F: $\pm 1\%$ G: $\pm 2\%$ J: $\pm 5\%$	T: Taping Reel B: Bulk	E: $\pm 100$ F: $\pm 200$ G: $\pm 300$ H: $\pm 400$ J: $\pm 600$ K: $\pm 150$ R: $\pm 1000$	: Standard A: 1.5W Q: 3/4W S: 2W T: 1W U: 1/2W V: 1/4W W: 1/8W	R010: 0.01 $\Omega$ R100: 0.1 $\Omega$ 1R00: 1 $\Omega$	: Standard N: No Marking W: Wide

## Derating Curve

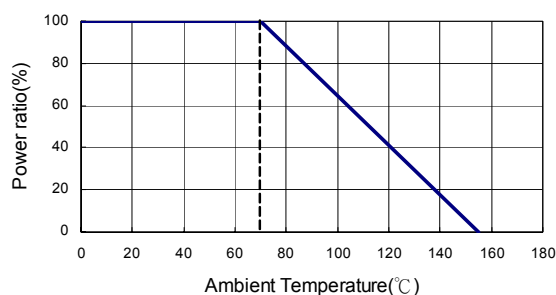

## Standard Electrical Specifications

Type	Item	Power Rating at 70°C	Operating Temp. Range	Resistance Range (mΩ)			TCR (PPM/°C)
				±1%	±2%	±5%	
CS01 (0201)		1/20W	-55 ~ +155°C	100 - 149 150 - 500 501 - 1000			±1000 ±600 ±300
CS02 (0402)		1/16W		50 - 100 101 - 500 501 - 1000			±400 ±300 ±200
CS03 (0603)		1/10W		20 - 50 51 - 100 101 - 500 501 - 1000			±600 ±400 ±300 ±200
CS05 (0805)		1/8W		20 - 50 51 - 100 101 - 500 501 - 1000			±600 ±400 ±300 ±200
CS06 (1206)		1/4W		10 - 20 21 - 50 51 - 99 100 - 1000			±600 ±400 ±300 ±200
CS13 (1210)		1/2W					
CS10 (2010)		3/4W					
CS12 (2512)		1W					
CS25 (1225)		3W		3 - 5 6 - 20 21 - 30 31 - 250 251 - 8000			±300 ±200 ±150 ±100 ±200
CS37 (3720)		1W		10 - 19 20 - 500			±300 ±150
CS75 (7520)		2W		—      1 - 4			±300
				5 - 10 11 - 350			±200 ±150

## High Power Rating Electrical Specifications

Type	Item	Power Rating at 70°C	Operating Temp. Range	Resistance Range (mΩ)			TCR (PPM/°C)
				±1%	±2%	±5%	
CS02 (0402)		1/8W	-55 ~ +155°C	51 - 100 101 - 500 501 - 1000			±400 ±300 ±200
CS03 (0603)		1/8W					
CS05 (0805)		1/4W					
CS06 (1206)		1/2W	-55 ~ +155°C	10 - 20 21 - 50 51 - 99 100 - 1000			±600 ±400 ±300 ±200
CS13 (1210)		3/4W					
CS10 (2010)		1W					
CS12 (2512)		1.5W					
CS12 (2512)		2W					

## Low TCR Electrical Specifications

Type	Item	Power Rating at 70°C	Operating Temp. Range	Resistance Range (mΩ)			TCR (PPM/°C)
				±1%	±2%	±5%	
CS05 (0805)		1/8W	-55 ~ +155°C	100 - 1000			±100
CS06 (1206)		1/4W		100 - 1000			±100
CS13 (1210)		1/2W		75 - 1000			±100
CS10 (2010)		3/4W		50 - 1000			±100
CS12 (2512)		1W		20 - 1000			±100
CS12 (2512)		2W		50 - 1000			±100
CS37 (3720)		1W		100 - 500			±100
CS75 (7520)		2W		50 - 350			±100

Operating Voltage= $\sqrt{P \cdot R}$  ; Overload Voltage= $2.5 \cdot \sqrt{P \cdot R}$  ; Operating Current= $\sqrt{P/R}$

■ Viking is capable of manufacturing the optional spec based on customer's requirement.

## Marking for 0603

Codes	Type
1R0	1.000Ω
R10	0.100Ω
R01	0.010Ω
<u>101</u>	0.101Ω
<u>035</u>	0.035Ω

## ■ Environmental Characteristics

Item	Requirement	Test Method
Temperature Coefficient of Resistance (T.C.R.)	As Spec.	-55°C~+125°C, 25°C is the reference temperature
Short Time Overload	$\pm(0.5\%+0.05\Omega)$	RCWV*2.5 or Max. overload voltage for 5 seconds
	$\pm(1.0\%+0.05\Omega)$ for high power rating	
Insulation Resistance	$\geq 10G$	Max. overload voltage for 1 minute
Endurance	$\pm(1.0\%+0.05\Omega)$	70 $\pm$ 2°C, Max. working voltage for 1000 hrs with 1.5 hrs "ON" and 0.5 hrs "OFF"
Damp Heat with Load	$\pm(0.5\%+0.05\Omega)$	40 $\pm$ 2°C, 90~95% R.H. Max. working voltage for 1000 hrs with 1.5 hrs "ON" and 0.5 hrs "OFF"
Dry Heat	$\pm(0.5\%+0.05\Omega)$	at +155°C for 1000 hrs
Bending Strength	As Spec.	Bending once for 5 seconds 2010, 2512 sizes: 2mm Other sizes: 3mm
Solderability	95% min. coverage	245 $\pm$ 5°C for 3 seconds
Resistance to Soldering Heat	$\pm(0.5\%+0.05\Omega)$	260 $\pm$ 5°C for 10 seconds
Voltage Proof	No breakdown or flashover	1.42 times RCWV (RMS) for 1 minute
Leaching	Individual leaching area $\leq 5\%$ Total leaching area $\leq 10\%$	260 $\pm$ 5°C for 30 seconds
Rapid Change of Temperature	$\pm(0.5\%+0.05\Omega)$	-55°C to +155°C, 5 cycles

■ Reference Standards: IEC 60115-1, 60068-2-58; JIS-C 5201-1

■ Storage Temperature: 25 $\pm$ 3°C; Humidity < 80%RH

## ■ Packaging

Packaging Quantity & Reel Specifications

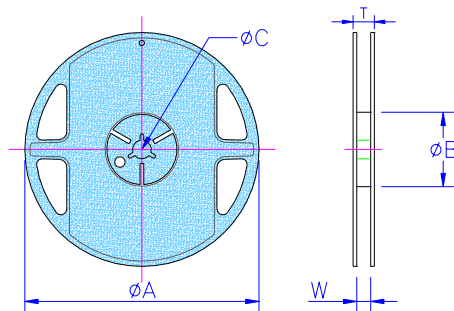

Unit: mm

Type	ΦA	ΦB	ΦC	W	T	Paper Tape (EA)	Embossed Plastic Tape (EA)
CS01	178.0 $\pm$ 1.0	60.0 + 1.0	13.5 $\pm$ 0.7	9.5 $\pm$ 0.1	11.5 $\pm$ 1.0	10,000	-
CS02	178.0 $\pm$ 1.0	60.0 + 1.0	13.5 $\pm$ 0.7	9.5 $\pm$ 0.1	11.5 $\pm$ 1.0	10,000	-
CS03	178.0 $\pm$ 1.0	60.0 + 1.0	13.5 $\pm$ 0.7	9.5 $\pm$ 0.1	11.5 $\pm$ 1.0	5,000	-
CS05	178.0 $\pm$ 1.0	60.0 + 1.0	13.5 $\pm$ 0.7	9.5 $\pm$ 0.1	11.5 $\pm$ 1.0	5,000	-
CS06	178.0 $\pm$ 1.0	60.0 + 1.0	13.5 $\pm$ 0.7	9.5 $\pm$ 0.1	11.5 $\pm$ 1.0	5,000	-
CS13	178.0 $\pm$ 1.0	60.0 + 1.0	13.5 $\pm$ 0.7	9.5 $\pm$ 0.1	11.5 $\pm$ 1.0	5,000	-
CS10	178.0 $\pm$ 1.0	60.0 + 1.0	13.5 $\pm$ 0.7	13.5 $\pm$ 1.0	15.5 $\pm$ 1.0	-	4,000
CS12	178.0 $\pm$ 1.0	60.0 + 1.0	13.5 $\pm$ 0.7	13.5 $\pm$ 1.0	15.5 $\pm$ 1.0	-	4,000
CS12 (2W)	178.0 $\pm$ 1.0	60.0 + 1.0	13.5 $\pm$ 0.7	13.5 $\pm$ 1.0	15.5 $\pm$ 1.0	-	2,000
CS25	178.0 $\pm$ 1.0	60.0 + 1.0	13.5 $\pm$ 0.7	13.5 $\pm$ 1.0	15.5 $\pm$ 1.0	-	2,000
CS37	178.0 $\pm$ 1.0	60.0 + 1.0	13.5 $\pm$ 0.7	13.5 $\pm$ 1.0	15.5 $\pm$ 1.0	-	2,000
CS75	178.0 $\pm$ 1.0	60.0 + 1.0	13.5 $\pm$ 0.7	17.5 $\pm$ 1.0	19.5 $\pm$ 1.0	-	2,000

Paper Tape Specifications

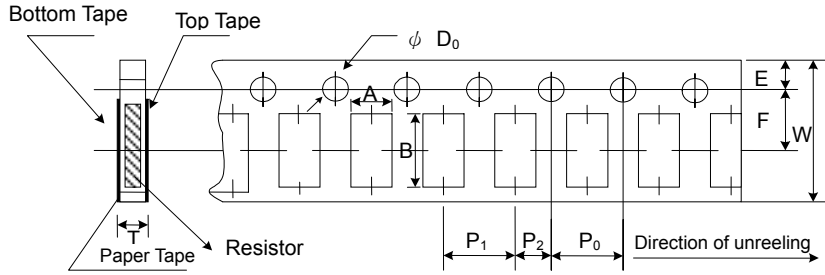

Unit: mm

Type	A	B	W	E	F	P <sub>0</sub>	P <sub>1</sub>	P <sub>2</sub>	ΦD <sub>0</sub>	T
CS01	0.38±0.05	0.68±0.05	8.0±0.20	1.75±0.10	3.50±0.05	4.00±0.10	2.00±0.05	2.00±0.05	1.50+0.1,-0	0.42±0.20
CS02	0.65±0.10	1.15±0.10	8.0±0.20	1.75±0.10	3.50±0.05	4.00±0.10	2.00±0.05	2.00±0.05	1.50+0.1,-0	0.45±0.10
CS03	1.10±0.10	1.90±0.10	8.0±0.20	1.75±0.10	3.50±0.05	4.00±0.10	4.00±0.05	2.00±0.05	1.50+0.1,-0	0.70±0.10
CS05	1.60±0.10	2.40±0.20	8.0±0.20	1.75±0.10	3.50±0.05	4.00±0.10	4.00±0.05	2.00±0.05	1.50+0.1,-0	0.85±0.10
CS06	1.90±0.10	3.50±0.20	8.0±0.20	1.75±0.10	3.50±0.05	4.00±0.10	4.00±0.05	2.00±0.05	1.50+0.1,-0	0.85±0.10
CS13	2.90±0.10	3.50±0.20	8.0±0.20	1.75±0.10	3.50±0.05	4.00±0.10	4.00±0.05	2.00±0.05	1.50+0.1,-0	0.85±0.10

Embossed Plastic Tape Specifications

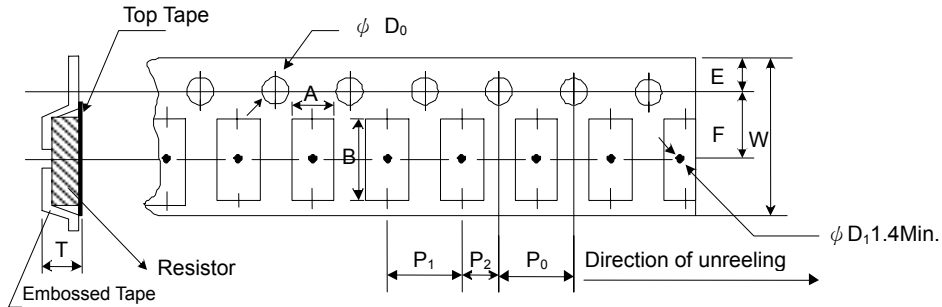

Unit: mm

Type	A	B	W	E	F	P <sub>0</sub>	P <sub>1</sub>	P <sub>2</sub>	ΦD <sub>0</sub>	T
CS10	2.80±0.10	5.50±0.10	12.0±0.10	1.75±0.10	5.5±0.05	4.00±0.05	4.00±0.10	2.00±0.05	1.50+0.10	1.00±0.20
CS12	3.50±0.10	6.70±0.10	12.0±0.10	1.75±0.10	5.5±0.05	4.00±0.05	4.00±0.10	2.00±0.05	1.50+0.10	1.00±0.20
CS12 (2W)	3.38±0.10	6.68±0.10	12.0±0.30	1.75±0.10	5.5±0.10	4.00±0.10	4.00±0.10	2.00±0.05	1.55+0.05	1.45±0.20
CS25	3.38±0.10	6.68±0.10	12.0±0.30	1.75±0.10	5.5±0.10	4.00±0.10	4.00±0.10	2.00±0.05	1.55+0.05	1.45±0.20
CS37	2.50±0.20	4.45±0.20	12.0±0.30	1.75±0.10	5.5±0.05	4.00±0.05	4.00±0.10	2.00±0.05	1.50+0.20	1.20±0.20
CS75	2.50±0.20	8.30±0.20	16.0±0.30	1.75±0.10	7.8±0.05	4.00±0.05	4.00±0.10	2.00±0.05	1.50+0.20	1.20±0.20

Recommend Land Pattern

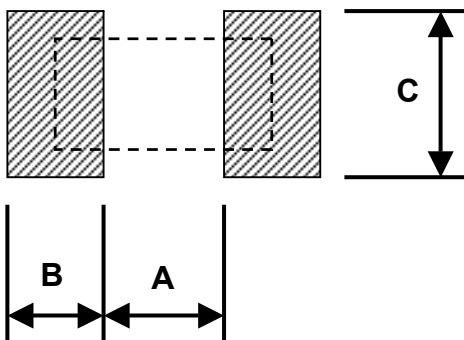

Pad Layout (Except For CS12: High Power Rating Series)

Unit: mm

Type	A	B	C
CS01	0.25	0.30	0.40±0.2
CS02	0.50	0.50	0.60±0.2
CS03	0.80	1.00	0.90±0.2
CS05	1.00	1.00	1.35±0.2
CS06	2.00	1.15	1.70±0.2
CS13	2.00	1.15	2.50±0.2
CS10	3.60	1.40	2.50±0.2
CS12	4.90	1.60	3.10±0.2
CS25	2.00	2.00	6.40±0.2
CS37	1.00	1.80	3.90±0.2
CS75	1.00	1.80	7.60±0.2

Pad Layout (For CS12: High Power Rating Series)

Unit: mm

Type	Resistance Range	A	B	C
CS12	10 - 99mΩ	4.9	1.6	3.1±0.2
CS12	100 - 1000mΩ	1.0	3.55	3.1±0.2